

# Packaging Specifications of Tube Pack for TO-220

1. The method of packaging and dimension are shown as below figure. (Dimension in mm)

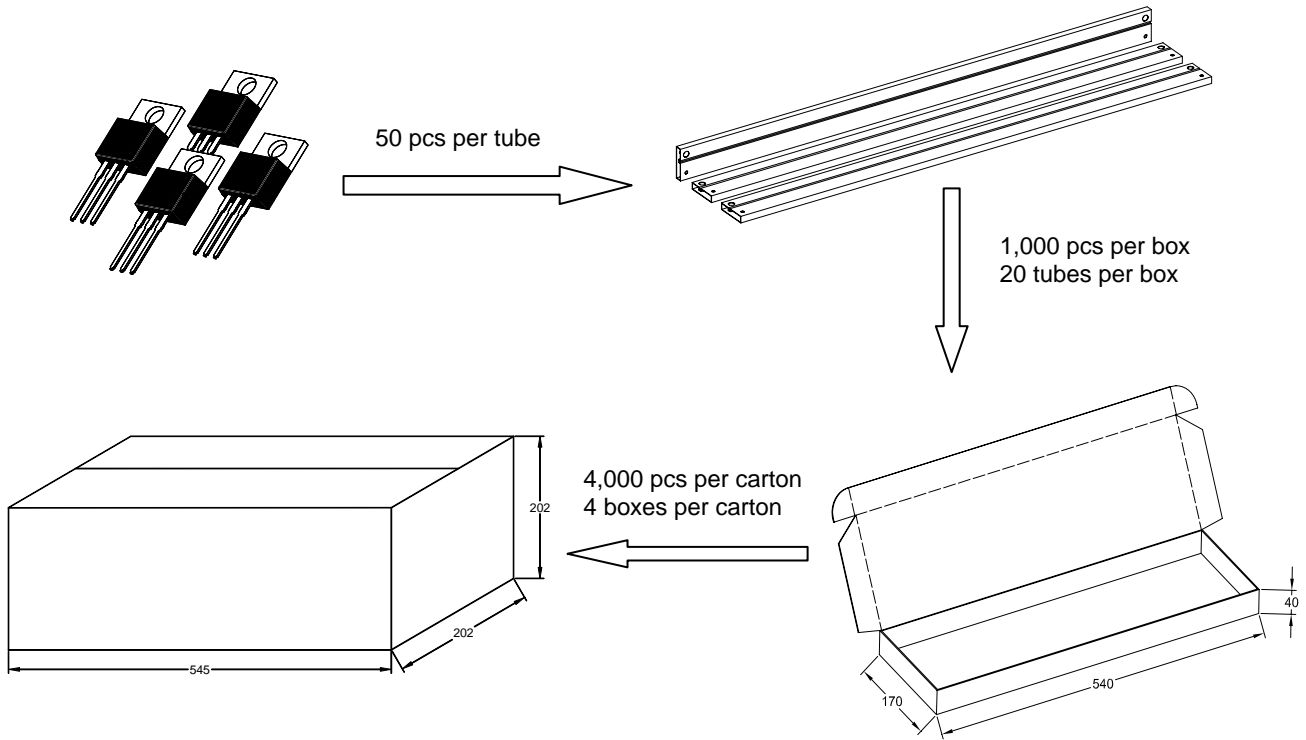

2. Tube data (Units: mm)

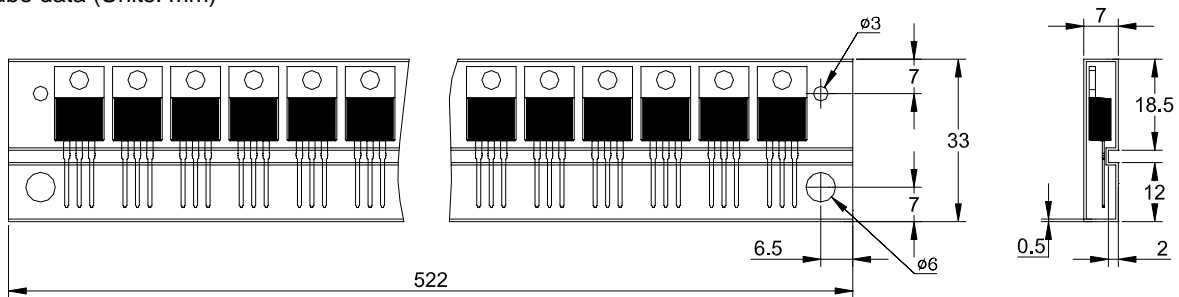

3. Label

3.1 The information of box label must be listed:

- 3.1.1 TYPE
- 3.1.2 QTY
- 3.1.3 LOT NO.
- 3.1.4 RMK

3.2 The information of carton label must be listed:

- 3.2.1 TYPE
- 3.2.2 QTY
- 3.2.3 P.O.

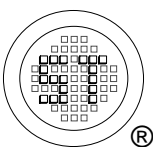

**SEMTECH ELECTRONICS LTD.**  
Subsidiary of Sino-Tech International (BVI) Limited



Dated : 26/11/2010 Rev:01