

Packaging Specifications of 26 mm Ammo Pack for Lead Type Diodes

1. The method of packaging and dimension are shown as below figure. (Dimension in mm)

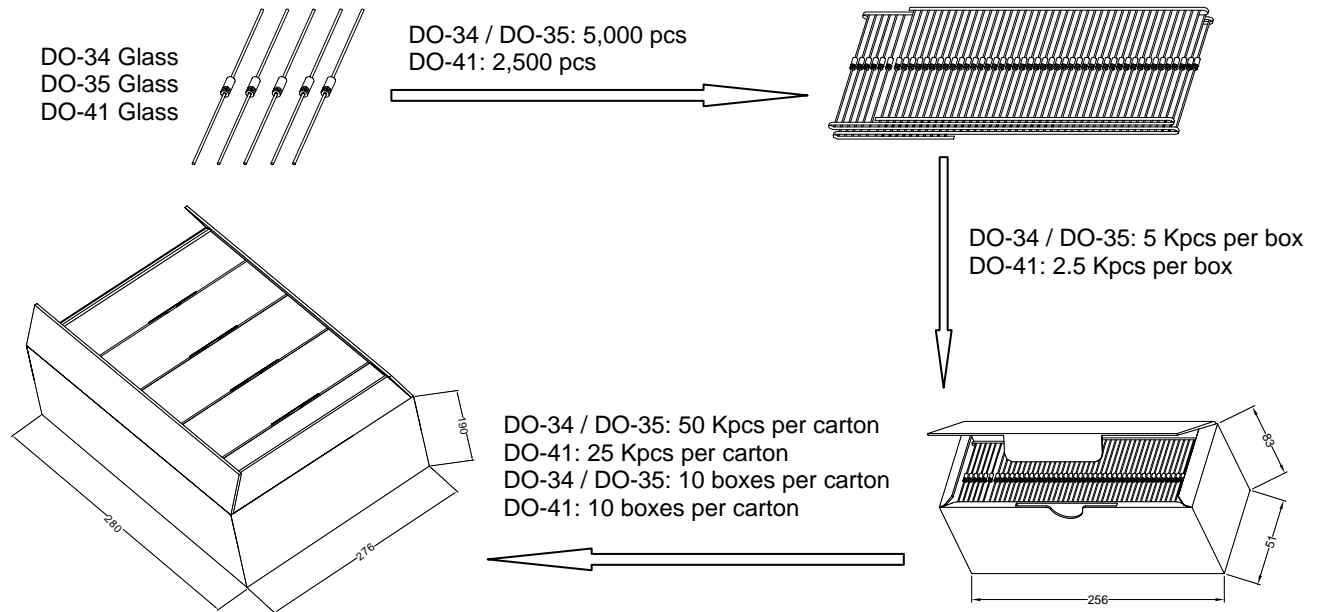

2. Dimension of taping.

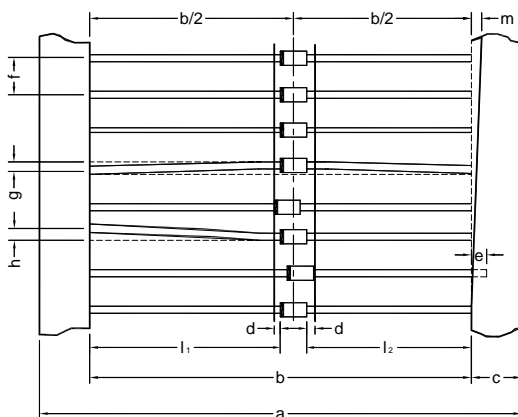

Units in mm

b	26.25 ±0.25
c	6.25 ±0.25
f	5 ±0.3
g	1 max.
h	1 max.
l ₁ -l ₂	1 max.
m	0.8 max.

3. Label

3.1 The information of inner box label must be listed: (Description of a sample lable)

- 3.1.1 **TYPEBZX55C2V0** means (Product) TYPE (Part No.)
- 3.1.2 **QTY 10,000 PCS** means (Product) Quantity (QTY)
- 3.1.3 **D/C TT0C2H0129Z020** means Dice Lot No. / Code (D/C)
- 3.1.4 **P/C 80092032** means Production Code (P/C)
- 3.1.5 **RMK80303 G PX H** = means Manufacturing Date (RMK)

3.2 The information of carton label must be listed:

- 3.2.1 TYPE
- 3.2.2 QTY

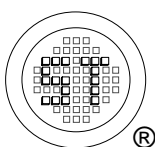

SEMTECH ELECTRONICS LTD.
Subsidiary of Sino-Tech International (BVI) Limited



Dated : 22/11/2010 Rev:01