

Condition of Soldering for Transistor & Diode

• Recommended condition of flow soldering

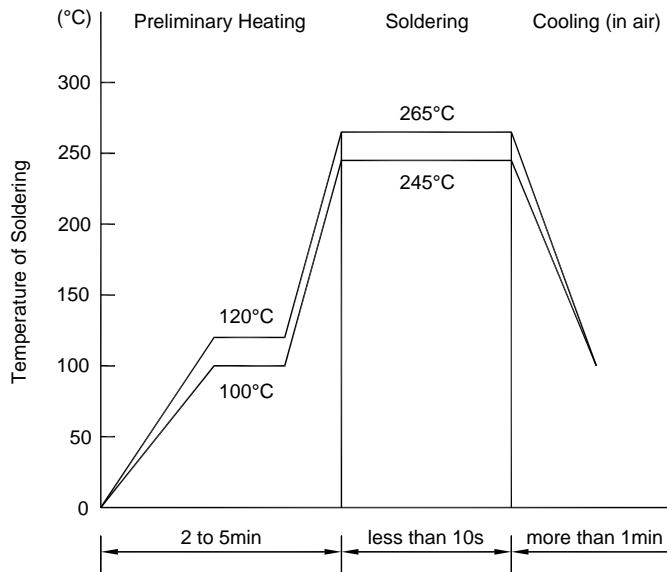

• Recommended condition of reflow soldering

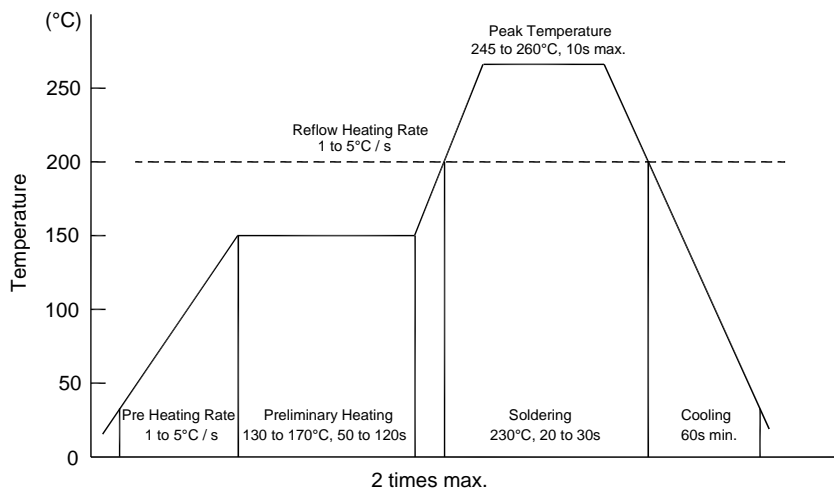

Recommended peak temperature is over 245 °C. If peak temperature is below 245 °C, you may adjust the following parameters; time length of peak temperature (longer), time length of soldering (longer), thickness of solder paste (thicker)

• Condition of hand soldering

Temperature: 370 °C

Time: 3s max.

Times: one time

• Remark: Lead free solder paste (96.5Sn/3.0Ag/0.5Cu)

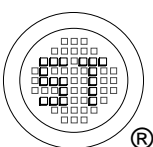

SEMTECH ELECTRONICS LTD.
 Subsidiary of Sino-Tech International (BVI) Limited



Reference to Copper Plate Area Dimension on PCB

Units: in mm

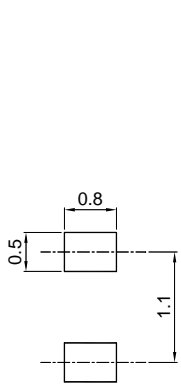

SOD-723

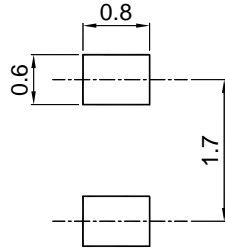

SOD-523

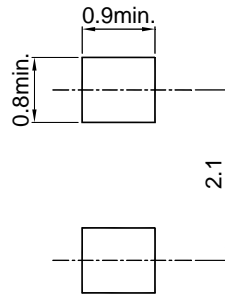

SOD-323

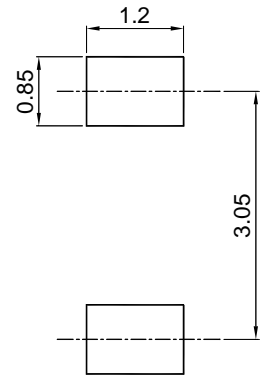

SOD-123

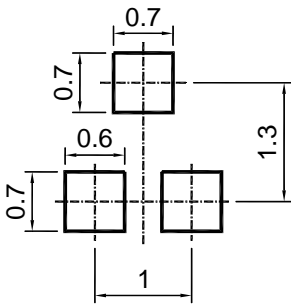

SOT-523

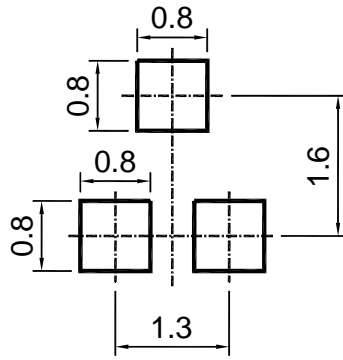

SOT-323

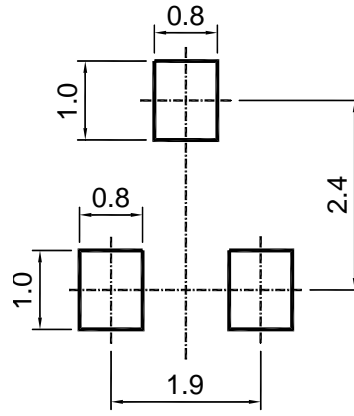

SOT-23

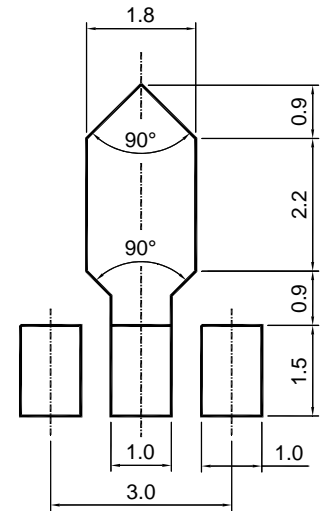

SOT-89

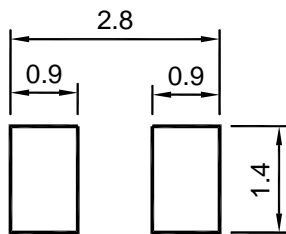

LS-31 (Micro MELF)

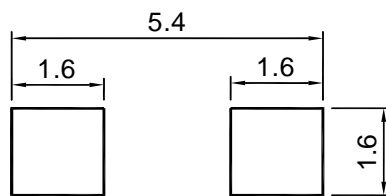

LL-34 (Mini MELF)
DO-213AA (Mini MELF)
LS-34 (Quadro MELF)

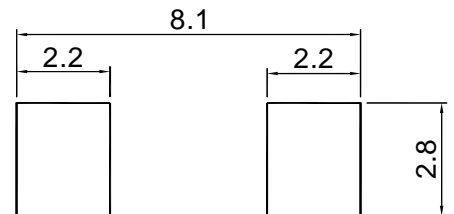

LL-41 (MELF)
DO-213AB (MELF)

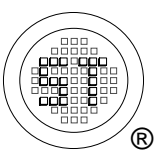

SEMTECH ELECTRONICS LTD.
Subsidiary of Sino-Tech International (BVI) Limited

